

TH-03/04/05/07

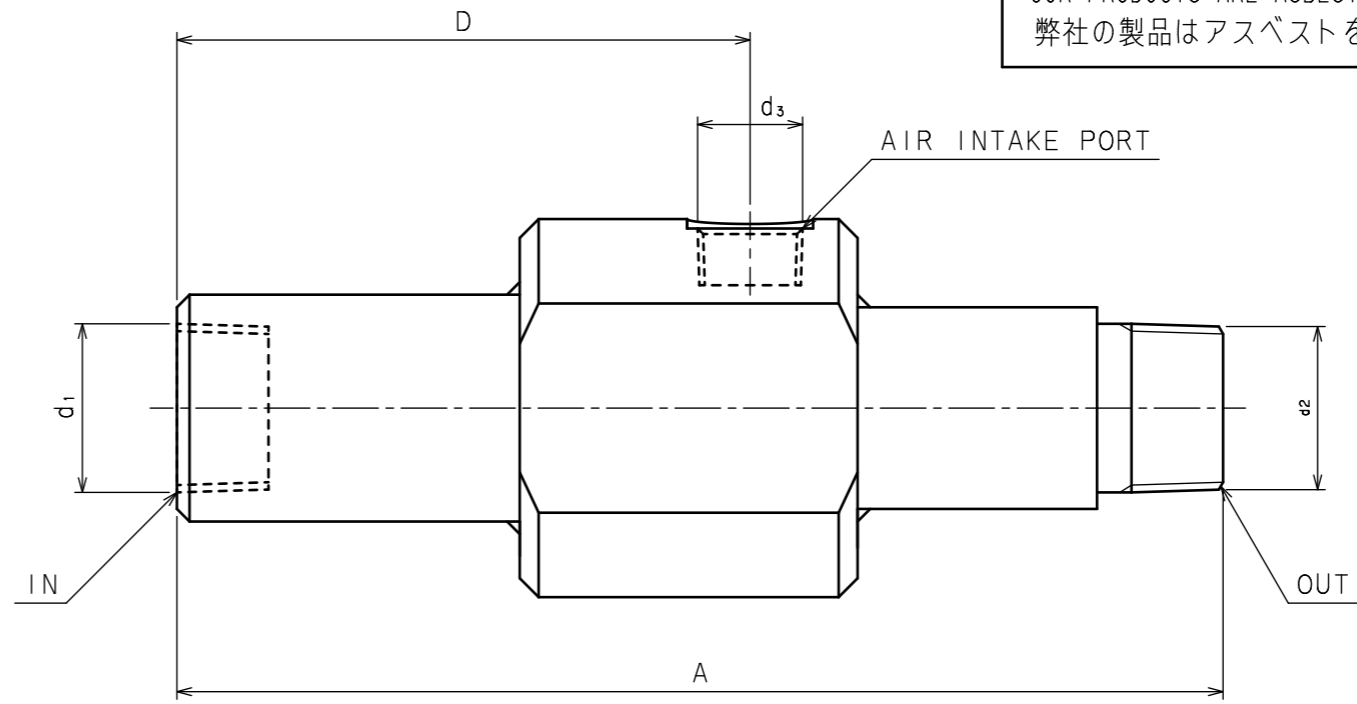

OUR PRODUCTS ARE ASBESTOS-FREE (INCLUDING PACKAGING MATERIALS)
 弊社の製品はアスベストを一切使用しておりません (梱包材も含む)

TH-10

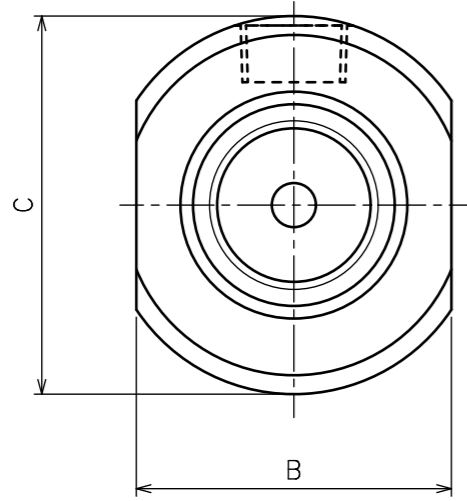
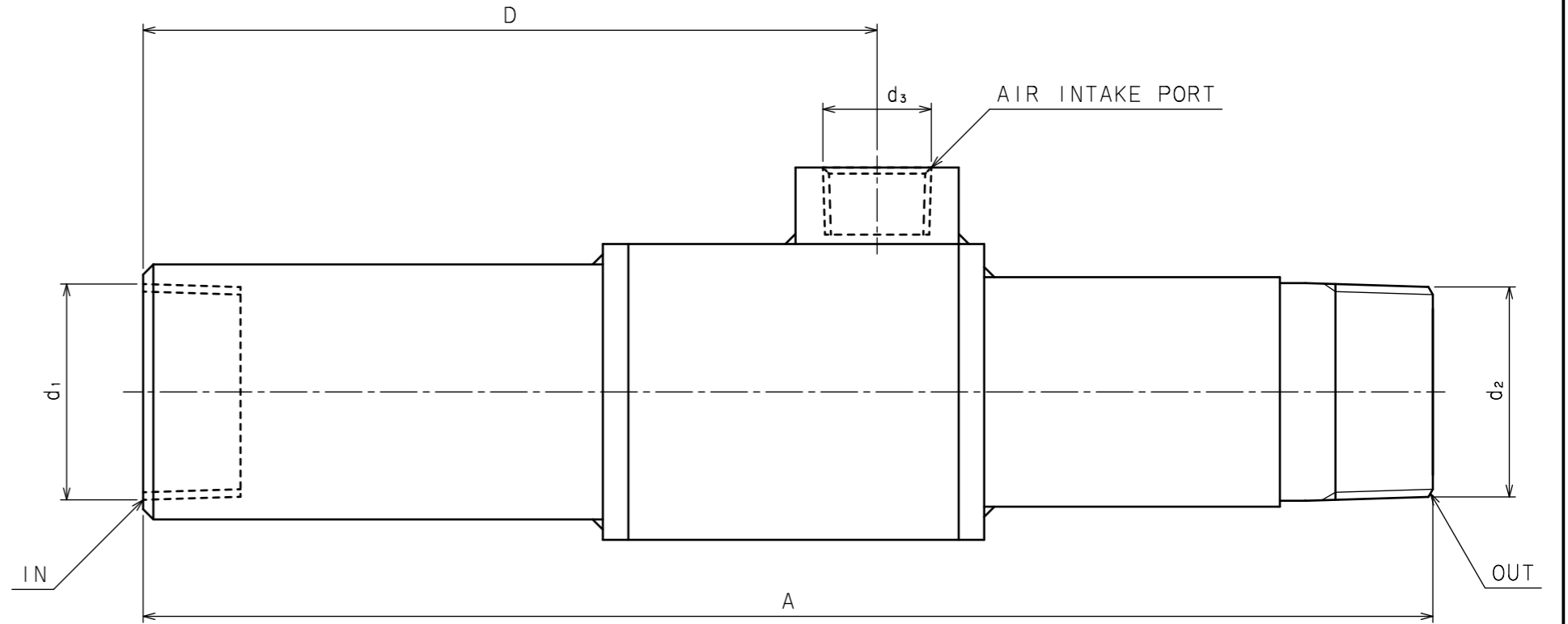
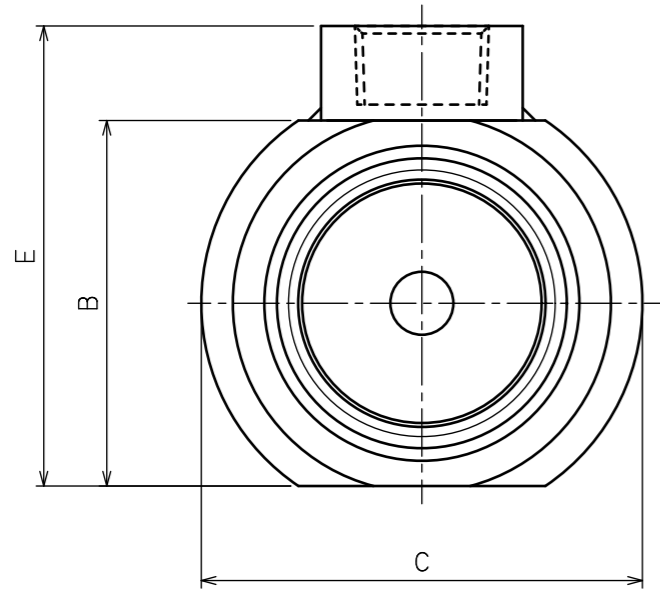

MARK MODEL 符号 型式	MATERIAL 材質	STANDARD PRESS. 標準圧力	STANDARD FLOW RATE 標準流量	MASS 質量	A (mm)	B (mm)	C (mm)	D (mm)	E (mm)	INNER DIAMETER 口径		
										d ₁	d ₂	d ₃
TH-03	SUS304	0.2 MPa	8 L/min	0.25 kg	77	27	33	46	-	R1/4	Rc1/4	Rc1/8
TH-04	SUS304	0.2 MPa	15 L/min	0.43 kg	102.5	33	40	61.5	-	R3/8	Rc3/8	Rc1/8
TH-05	SUS304	0.2 MPa	24 L/min	0.80 kg	127	41	50	74	-	R1/2	Rc1/2	Rc1/4
TH-07	SUS304	0.2 MPa	46 L/min	1.5 kg	166	50	60	91	-	R3/4	Rc3/4	Rc3/8
TH-10	SUS304	0.2 MPa	94 L/min	3.2 kg	253	58	70	144	73	R1-1/4	Rc1-1/4	Rc1/2

APPROVED BY/承認 K. IWAMI	CHECKED BY/確認 ---	DESIGNED BY/設計 ---	DRAWN BY/描 N. SHI NOHARA	DATE DRAWN/描日 AUG. 16, 2021	HELIX NOZZLE
SCALE/縮尺 NTS	TAISEIKOGYO CO., LTD.			MODEL CODE/型式 TH	REV. 0